

Powerwall Dolly

The Powerwall dolly is custom-designed to lift and transport Powerwall. Pneumatic wheels, hydraulic disc brakes, and slide rails ensure the dolly can cross rough terrain and descend stairs. The dolly interfaces directly with Powerwall to hold it secure, and a battery-powered drill¹ is used to drive the lifting mechanism to raise and lower Powerwall with ease.

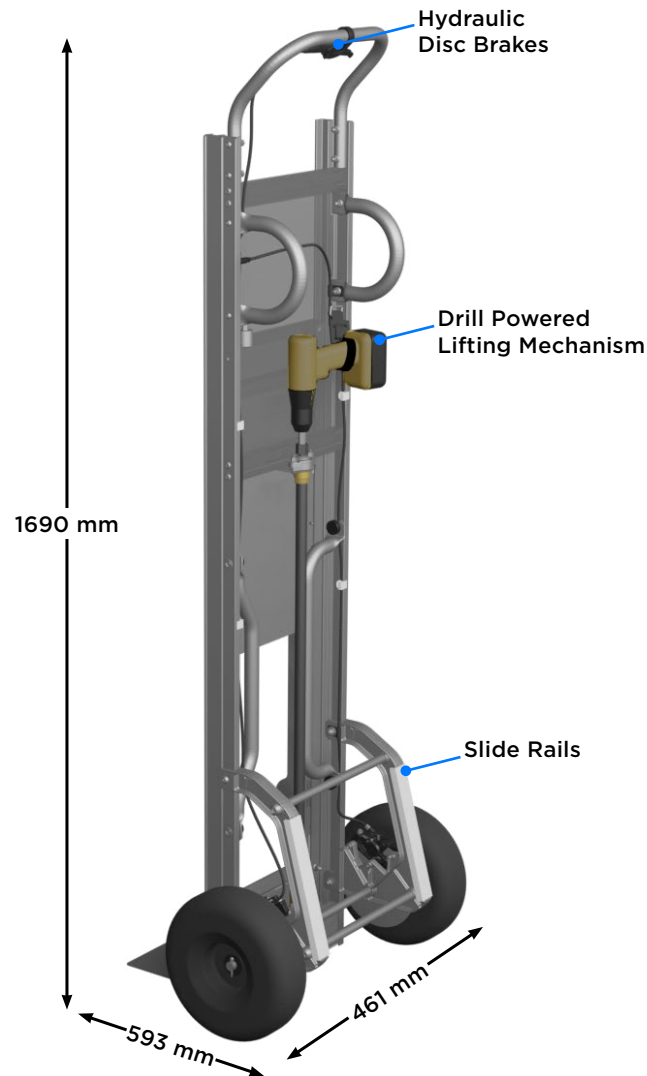

Specifications

Dolly Dimensions	1690 x 593 x 461 mm
Dolly Weight	24 kg
Maximum Install Height	686 mm to base of Powerwall
Maximum Lift Capacity	136 kg
Lifting Mechanism	Lifting screw via 19 mm socket
Lifting Power Source	Battery-powered drill (no impact drivers) ¹
Brake Type	Single lever actuated dual hydraulic disc brakes
Wheel Type	Pneumatic tires
Model Number	1856187-xx-y
Powerwall Compatibility	Powerwall 2, Powerwall 3

¹Drill not included with dolly.